



## GENERAL FEATURES

- Rack size **35x35 cm**
- Gross weight: 39 Kg
- Washing cycle / racks/hour: 120" / 30
- Bottom wash/rinse arm
- Top rinse arm
- Wash pump: 190 W
- Boiler capacity: 3 liters
- Tank capacity: 10 liters
- Boiler heating element: 2,7 Kw
- Tank heating element: 2,4 Kw
- Water quantity per cycle: 2 liters
- Electromechanical controls
- Useful washing height: 250 mm
- Magnetic door microswitch
- Automatic water filling
- Built-in rinse-aid dispenser (adjustable)
- Hot rinse
- Thermostop system
- Anti back-flow valve

## FILTRATION

- Plastic wash pump filter, easily removable

## BODY

- AISI 304 stainless steel Body
- Single skinned body
- Preformed wash tank
- Double skinned door
- Door handle in s/s
- Wash/rinse arms in s/s, easily removable
- Boiler in s/s AISI 304
- PVC protection rear the bottom front panel

## EQUIPMENT AS GLASSWASHER

- 2 glass racks 35x35 cm
- 1 cutlery small basket
- 1 insert for saucers
- 1 inlet hose (length 2 mt)
- 1 drain hose (length 2,5 mt)

## OPTIONAL

- Electric detergent dispenser
- Drain pump
- Hot water filling
- 60 Hz version
- Kit 4 high feet

## ACCESSORIES FOR THE WATER TREATMENT

- Internal water softener ("S" version)

## ACCESSORIES

- Special racks (Round, diam. cm.35)

## INSTALLATION

- Use the screws of the feet and a spirit level to ensure that the machine is levelled

## MAIN POWER SUPPLY

- The voltage of main power supply must be compatible with the rated voltage
- The machine must be connected to a suitable earth (ground) system
- Connect the machine power socket to the multi-pole wall switch provided

## WATER SUPPLY CONNECTION

- A water softener must be installed if the water is hard
- The water pressure must be between 0.2MPa (2 bar), and, 0.5MPa (5 bar)
- The temperature of the water-supply must be between 10°C to 50°C

## SPECIFICHE TECNICHE

- Voltage: **220-240 V ~ 50 Hz**
- Total power: **2,89 kW**
- Amperage: **13 A**
- Power cord supply size: **3 x 1,5 mmq**

## AF 35.25

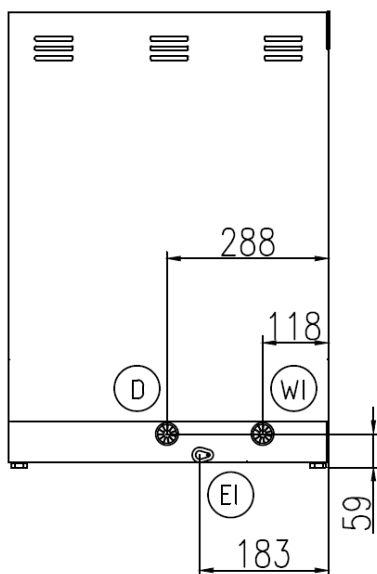
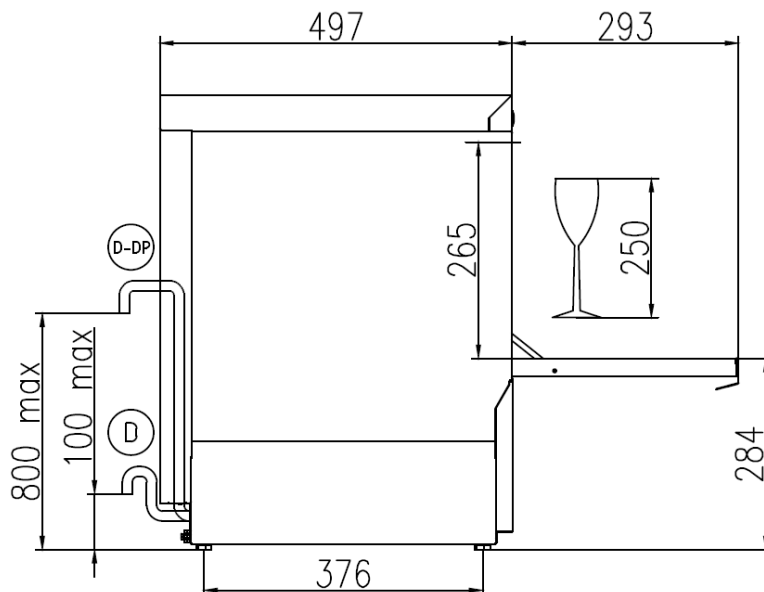
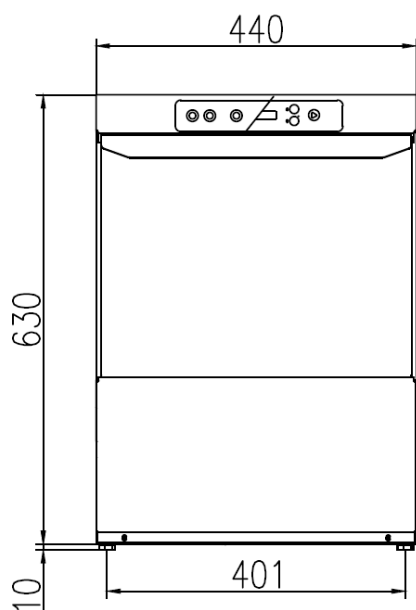

- EI
 CAVO DI ALIMENTAZIONE  
 POWER CORD SUPPLY  
 CABLE D'ALIMENTATION  
 CABLE DE ALIMENTACION
  
- WI
 CANNA DI CARICO G 3/4 L=2000 mm  
 G 3/4 INLET HOSE L=2000 mm  
 TUYAU D'ALIMENTATION G 3/4" L=2000 mm  
 TUBO DE ALIMENTACION G 3/4" L=2000 mm
  
- D
 TUBO DI SCARICO ø 29 mm L=2500 mm  
 DRAIN HOSE ø 29 mm L=2500 mm  
 TUYAU DE VIDANGE ø 29 mm L=2500 mm  
 TUBO DE DESAGUE ø 29 mm L=2500 mm
  
- D-DP
 TUBO DI SCARICO ø 29 mm L=2500 mm (CON POMPA SCARICO)  
 DRAIN HOSE ø 29 mm L=2500 mm (WITH DRAIN PUMP)  
 TUYAU DE VIDANGE ø 29 mm L=2500 mm (AVEC POMPE DE VIDANGE)  
 TUBO DE DESAGUE ø 29 mm L=2500 mm (CON POMPA DE DESAGUE)

	Min 10°C-MAX 50°C
	Min 10°C-MAX 25°C with ENERGY RECOVERY
	200÷500kPa(2÷5 Bar)
	100÷500kPa(1÷5 Bar) with ATMOSPHERIC BOILER
	HARDNESS 5÷20f-2.8÷11'd