

IS 8-16 X - IS 12 VX

insaccatrici manuali manual sausage stuffers



- Corpo e cilindro in acciaio inox AISI 304.
- Pistone in nylon alimentare con valvola di sfogo aria.
- Scatola ingranaggi in acciaio zincato.
- Ingranaggi in acciaio temperato e rettificato.
- Scorrimento ingranaggi su 4 boccole.
- Sistema riduzione a doppia velocità.
- In dotazione: 3 imbuti in nylon alimentare bianco e morsetto fissaggio.

- AISI 304 S/S body and cylinder.
- Nylon pistons with air exhaust valve.
- Galvanized steel gear box.
- Ground and tempered steel gears.
- Gears sliding on 4 bushings.
- 2 speed gear reducer.
- Standard: 3 nylon filling tubes and fixing clamp.



IS 8-16 X

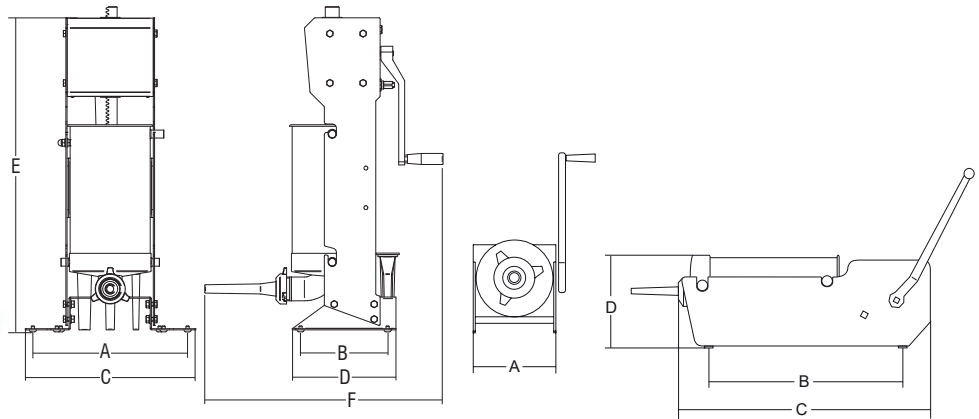

IS 12 XV

	lt	mm	ø mm	mm	ø mm	mm	mm	mm	mm	mm	mm	kg	mm	kg
IS 8 X	8	370	165	420	10-18-25	200	430	660	220	-	-	19	730x260x250	20
IS 16 X	16	500	200	560	10-18-25	240	575	820	250	-	-	23.5	890x310x280	24.5
IS 12 XV	12	380	200	420	10-18-25	400	190	435	250	794	602	24	890x310x280	26

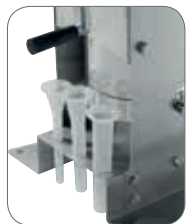

Porta imbuti
Holder funnels



IS 12 XV

Ribaltamento cilindro
Cylinder overturn

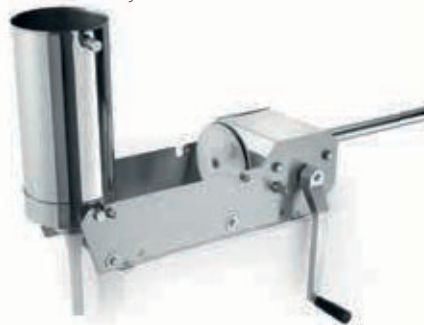

Estrema facilità di pulizia
Easy to clean



IS 8-16 X