



SINFONIA 2

macchina per la pasta fresca

pasta machine



- Adatta alle esigenze del piccolo e medio ristorante
- Pratica, veloce ed estremamente facile da pulire e sanificare
- Costruzione in acciaio inox AISI 304
- Potente motore ventilato con riduzione ad ingranaggi a bagno d'olio
- Performante pala impastatrice facilmente rimovibile
- Coperchio in acciaio inox interbloccato
- Pratica e rimovibile tramoggia per versare la parte liquida in modo ottimale
- Coclea, bocca e ghiera in acciaio inox
- Ampia disponibilità di trafilè in bronzo
- Vasca in alluminio anodizzato
- Comandi IP 54
- Sistema di ventilazione forzata anche a motore spento

Opzionali:

- Motorino tagliapasta con variatore di velocità.
- *Designed for medium-duty operations, ideal for small to medium-size restaurants*
- *Reliable, user-friendly and easy to clean.*
- *AISI 304 stainless steel body*
- *Powerful, air-cooled motor with oil bath gear box reducer*
- *High-performance and easy to remove kneading paddle*
- *Interlocked stainless steel lid*
- *Convenient removable funnel to add liquid ingredients during processing*
- *Stainless steel worm, head and ring*
- *Full availability of any kind of dies*
- *IP 54 controls*
- *Forced air-cooling system for heavy-duty use*

Options:

- Variable-speed pasta cutter



SINFONIA 2
con tagliapasta opzionale
optional pasta cutter

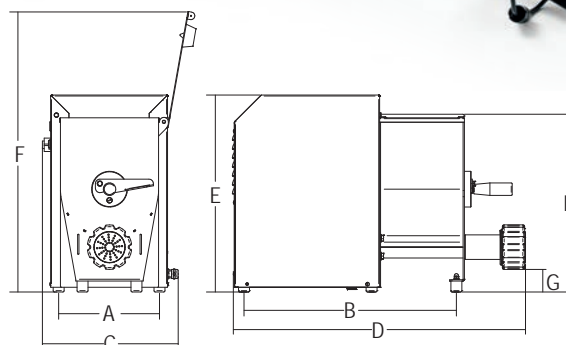

							A	B	C	D	E	F	G	H			
	watt/HP	lit	kg	kg/h.	ø mm	mm	mm	mm	mm	mm	mm	mm	mm	mm	kg	mm	kg
Sinfonia 2	370/0.50	1ph	6	2.1	4.2	59	206	411	263	577	407	489	65	353	28	750x580x800	37

Colore rosso opzionale
Optional red colour

